

SOLAR CHARGE CONTROLLER

for solar PV system

INSTRUCTION MANUAL



1 Characteristics

- Battery Ah setting
- Easy operating and setting
- Automatic selection of voltage 12/24V

Charging Control

- PWM charging
- Temperature compensation. Boost, equalizing, float charging
- Four work mode: ON/OFF, lighting control, Lighting + hours on, ON/OFF+exact time

Protecting Function

- TVS lightning protecting
- Over-load, short circuit, polarity reverse protection, electronic fuse.

Display

- LCD display specially designing for solar system
- LCD display: all system parameters in digital, system status assymbols
- Accurate clock

2 Controller panel instructions

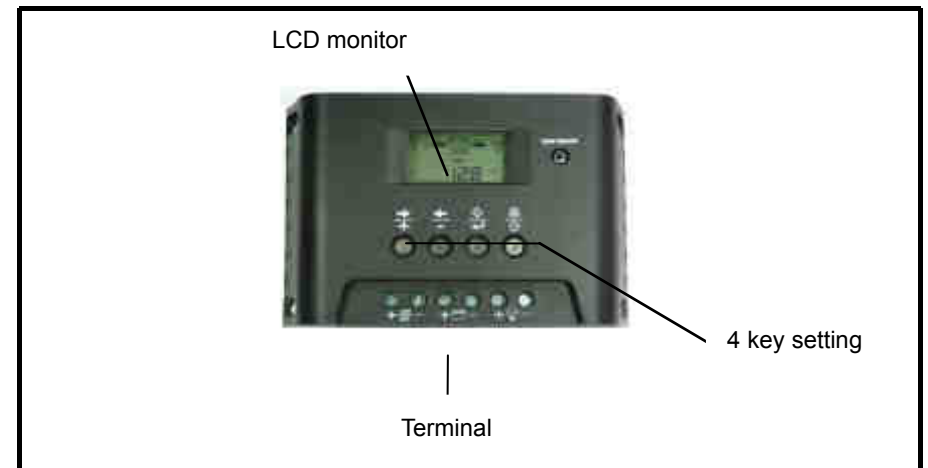

3 Installations:

Connect the individual components to the symbols provided, they are solar panel, battery and load in this order. Only install the regulator near the battery on a suitable surface. This surface should be solid, stable, even, dry and nonflammable. The battery cable should be as short as (1-2m) and have a suitable cable diameter size to minimize loss, e.g. use 2.5mm² at 10A; use 4mm² at 20A.

Observe the following connection sequence during commissioning

1) Mount the controller to a vertical surface. Allow space above and

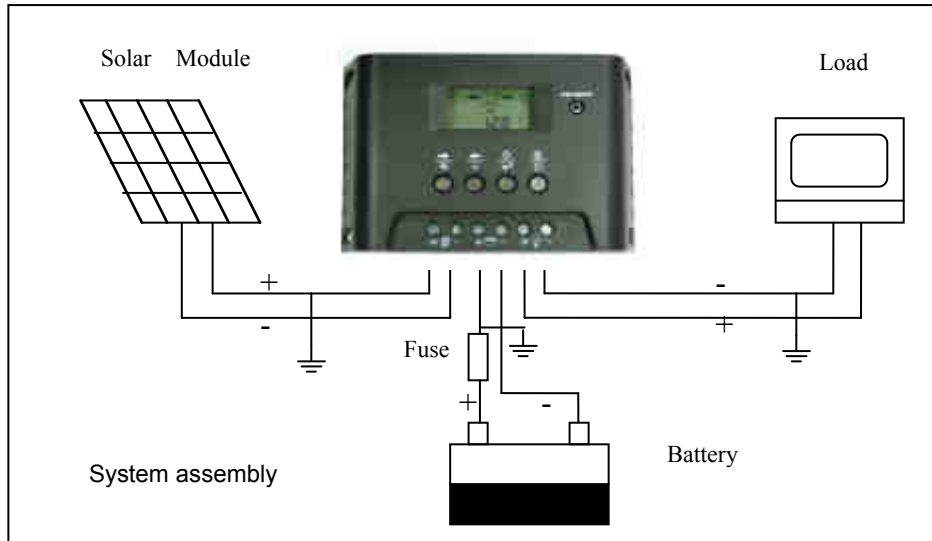

Below the controller for air flow. Note: the mounted ambient temperature should not be over the working temperature of controller
 □-10□~60□□□

2. Connect the polarity + of battery to the fuse and then connect the battery to the controller. The current of fuse should be chosen 3-4 times of rated current. Note the plus and minus.
3. Connect the photovoltaic module to the charge regulator - plus & minus
4. Connect the load to the charge regulator plus and minus

Please observe that the automatic adjustment to 12V/24V systems does not function properly, if this sequence order is not followed. An improper sequence order can damage the battery!





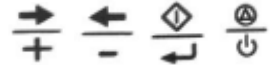

5. The parameters can be set depending on the users needs

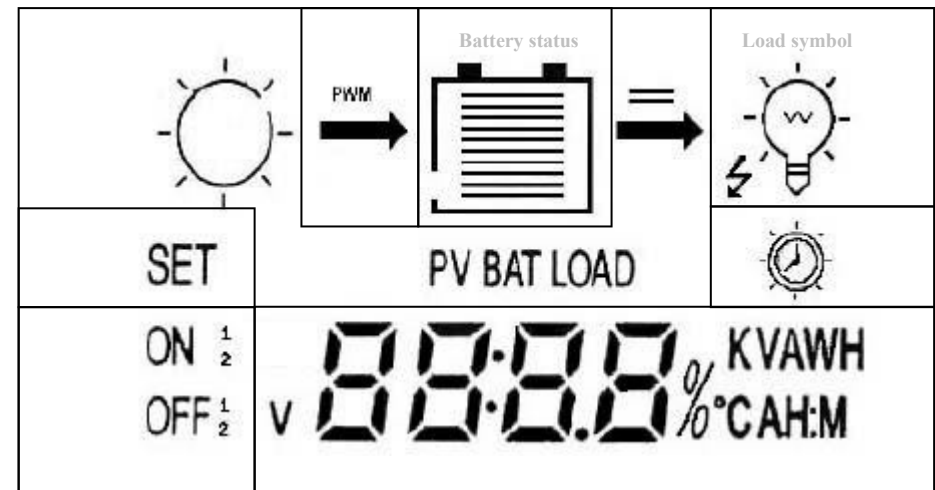
6. The negative battery is grounded or ground connected as the above.

4. Operation & instructions:

- 1 Keys & instructions (from left to right) 
- K1 □ Reading status, switch to next figure □ Setting status, switch to next function or increase the setting data.
- K2 □ Reading status, switch to the previous figure; setting status, switch to the previous function or decrease the setting data.
- K3: On reading status, press K3, then on setting status; on setting status, press K3, and save the data, back to reading status.
- K4 □ Cancel/power switch, on setting status, no saving with K4. On reading status, K4 is power switch while loads are working. Recovery key while its short-circuited or over load (with ON/OFF





- 2 Display instructions: LCD display as the setting mark:
 - 1 □  sun symbol,  on is daytime and  on is night time □  flashing shows over voltage.
 - 2 □ Charging mode  . PWM charging
 - 3 □  battery. The strips inside show the status of charging or discharging and current capacity percentage. If discharging, the strips will reduce.



If charging, the strips will increase.
Without charging or discharging, the strips inside will remain the same.

Every strips equals 10% of battery capacity.

 shows status of battery.  flashes when over discharging. It stops flashing when goes back to normal charging.

4  DC output.

5  load  shows load and trouble status.



 is on when the load is in normal,  symbol display when output is on.

Load symbol  is flashing when over loading, reduce the load, then press K4 to resume.

While short circuit protection,  flashes, returns to normal automatically after 10 minutes. If there are 2 short circuit protection in concession in 11 minutes, users needs to check loads and connections, then press K4.

6  LCD displays PV, BAT, Load for solar module, battery or load .

7 "SET" goes to reading status, "SET " flashing is on setting status

8)   , is the load ON or OFF symbol, for example, ON 1 is the first load on, OFF 2 is the second load switched off.

9  at bottom of LCD display shows parameters.

10)  Displays in lower right: V-Voltage, A-ampere, AH-Battery Capacity, °C -Temperature, H:M-Time

11) v XX% the percent of available battery voltage and the current capacity of the battery.

Please observe that the accuracy of the regulator s display is not comparable to that of a measuring device.

4. Operation instructions:

4  1 Reading specifications: On reading status, press K1, K2, LCD will repeat the following specifications.

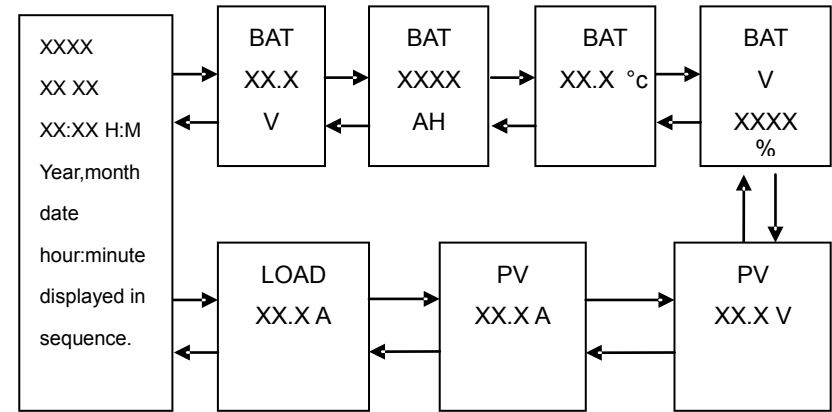

4.3 Battery capacity modify:







While display battery capacity XXXX AH, press K3 into setting mode, Battery unit AH & SET is flashing, modify the data through K1/K2, press once, battery capacity will be up/down 10, the maximum is 5000, the minimum is 50; Press K3 for saving or K4 to go back to reading status.

The default value is 500AH.

4.4 Load control setting

Four control mode: **lighting control, lighting+hours ON, ON/OFF on exact time, ON/OFF**, When LCD displays load current, press K3 and SET flashes. Operate K1, K2 to meet the users needs it will be displayed by icon on the right of the display. Press K3 to return to reading status.

Load control modes:

- 1)  , **lighting control**. The loads will be connected or disconnected automatically when the controller detects the light.
- 2)   **lighting+hours on**. The loads can start working automatically when the controller detects the light, hours off depends on the hours you set.
- 3)   **ON/OFF on exact time**. Load on or off on exact setting time.
- 4) Without  or  , its **ON/OFF mode**. The load output will be ON or OFF when you press the switch.

The default load mode is ON/OFF.

4.5 Time setting operation

Note: the whole time setting hours is 24 hours.

4.5.1 Real time adjustment

When LCD displays time to be adjusted:: Press K3 for two times and display SET
 Press K1 or K2 to change the year, month and day automatic and cycle
 Press K3, SET flashing, and modify the data by K1 and K2, note: only the last two numbers can be modified.
 Press K3 to confirm the modification and save the data; Press K4 to cancel the modification and return to the second step, and SET stop flashing.
 Press K4 two times and return to “reading status”, year, month, day, hour:minute will repeat in display ever 3 seconds.

4.5.2 Lighting + hours ON time adjustment

When LCD displays time to be adjusted:: Press K3 for two times and display SET
 Press K1 to display “on hours” see following:

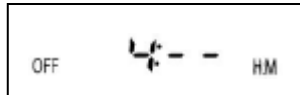

Press K3 for one time and SET flashes
 Modify the hours between 1~12 by K1 and K2
 Press K3 to confirm the modification and save the data; Press K4 to cancel the modification and return to the second step, and SET stops flashing.
 Press K4 for one time and turn to reading status

4.5.3 Exact time adjustment

When LCD displays time to be adjusted:: Press K3 for once and it returns to time display.
 Press K1,K2 to set the months of the first season.

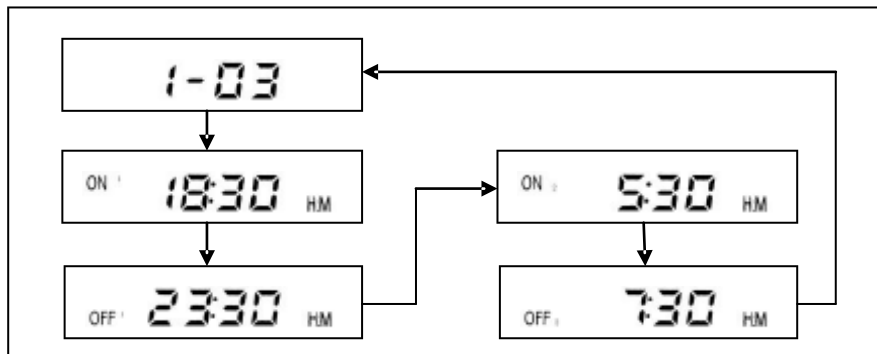

Press K3 for one time and it returns to the reading status for the first season.
 Press K1,K2, and it will display the months of first season, ON 1 and OFF 1, ON 2 and OFF 2, the arrowhead of the picture shows the display order.
 Press K1, K2 by
 Press K3 to confirm the modification and save the data, and return to the fourth step; Press K4 to cancel the modification and return to the fourth step, and SET stop flashing.

When modify Hour and Minute, H will be modified first. Press K3 and turn to M modification. Press K3 again, confirm the modification and save the data, and return to the fourth step; Press K4 to cancel the modification and return to the fourth step, and SET stop flashing.
 Press K4 for two times, and turn to reading status.
 The default time data is 0, and the controller will follow the last data setting.

The modification for the last month of the first season:
 When displaying the first season, press K3 for one time and SET flashing;
 Adjust data for month between 1~12 by K1-K2
 Press K3 to confirm or Press K4 to cancel. SET stop flashing, return to the fourth step above.
 Modification for H and M:
 When LCD displays time to be adjusted:
 of H:M flashes, user can modify hours
 User can adjust data 0~23 by K1/K2
 Press K3 again, save data of hours and then turn to modify

User can adjust data 0~59 by K1/K2.
 Press K3 and save the modified data, if not saved, then press K4 to return select status-

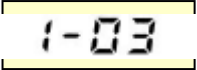
Note: the EXACT TIME Control can be divided to 4 seasons, for example:
 1 is the season no. 3 is the last month of season.
 Customers can also set 1-12, that means the whole year will have one season, and the controller will work same during the whole season.

Each season has two working periods. And shows as ON1□OFF1□ON2□OFF2. ON1, OFF1 for the first period, ON2, OFF2 is for the second period. The whole period is 24 hours. ON1 to OFF 2 is 24 hours.

5 Safety and Protection

The controller has intelligent protection against over voltage, overcurrent, short circuit, polarity reverse and lightning. The LCD display has warning indication for over voltage, over current and short circuit.

6 Guarantee & Customer service

One year warranty, Damaged caused by improper use or installation is not guaranteed.

7 Specifications

Rated charging current	10 (ma 12A)	15 (ma 18A)	20A(m 3A)
Rated load current □ Ie□	10A	15A	20A
Over load, short circuit protection	1.25 times of Ie for 60secs□1.5 times of Ie by for 5secs overload protection□ 3 time of the short circuit protection		
Self consumption	Control mode □ <15 mA, LED & LCD display <15mA□ Total: <30mA		
System voltage	12/24V AUTOWORK,		
Work temperature	industrial □ -20□ to 70°C		
Battery capacity	Battery in parallel from 50AH to 5000ah		
Boost charging	14.8V□ ×2/24V		
equalizing charging	14.4V□ ×2/24V		
Float charging	13.6V□ ×2/24V		
Low voltage disconnect	11. 1V□ × 2/24V		
Low voltage reconnect	12.5 V□ × 2/24V		
Temperature	5mv/°C /2v;		
Over discharge voltage	11.4V□ ×2/24V□ ×4/48V		
Control mode	PWM charging mode & ON/OFF mode for options, control point voltage is the intelligent compensation modify of the battery.		

8 Problems & Troubleshooting:

Problems	Troubleshooting
Sun symbol flashing without setting	Battery over voltage. Open circuit of battery. Check if the battery cable is connected properly , or disconnect all components and reconnect.
Battery symbol flashing without output	Over discharging
The load symbol flashing	Overload occurs, remove some loads and then press K4.
Load and short circuit symbol flashes	Short circuit protection □ check if the load is connected properly□remove any faulty Load then press K4.

8. MECHANICAL SPECIFICATIONS

