

Rutland Windcharger 913 & FM910-3 Land Tower & Rigging Kit Installation Instructions

CONTENTS

	Page
INTRODUCTION.....	2
CHECK YOU HAVE RECEIVED.....	3
WHAT YOU WILL NEED.....	3
SITING.....	4
FOUNDATIONS.....	5
Tower base.....	6
Guy Anchors.....	7
TOWER PREPARATION.....	8
ASSEMBLY.....	9
ERECTION.....	10
APPENDIX A – TUBE DRILLING DETAIL.....	11
APPENDIX B – SECTIONED TUBE KIT.....	12

INTRODUCTION

This manual contains important information concerning your Rutland 913 /FM910-3 Windcharger tower and its installation.

It is strongly recommended that you read this manual and familiarise yourself with its contents before installing and operating the Windcharger system.

The complete kit is a base pivoted 6.5m high twin guyed tower, for easy installation & erection by 2 people. The design complies with IEC1400-2.

The tower and rigging kits are available separately to allow the use of a single length of tube (supplied by the user) with the rigging kit. The customers own tower should be 40mm nominal medium (3.2 wall) galvanised tube. Inside diameter 41.7mm, outside diameter 48.1mm. Single length 6.5m.

WARNING!

- It is recommended that erection of the tower is only attempted in light winds.
- Standard Health & Safety working practices and appropriate personal protective equipment should be adopted during the following procedures.
- *When using the WG913, mounting pole outside diameter MUST NOT exceed 48.5mm. Larger section poles must not be used as this will reduce the tower to blade clearance. In high wind conditions this could cause damage to the windcharger by allowing the blade to come into contact with the mounting pole.*

CHECK YOU HAVE RECEIVED

Rigging kit CA-12/07

- Qty 2 - Tower Base brackets
- Qty 2 - Base Foundation 'U' bolts, washers & nuts
- Qty 4 - Guy Ground Anchors
- Qty 2 - Guy Tower Brackets
- Qty 2 - M8 x 65 Hex Head Bolts, Flat washers & Lock Nuts
- Qty 1 - M10 x 70 Hex Head Bolt, Flat washer & Lock Nut
- Qty 4 - 6.5m wire rope Guys with shackles fitted at looped end
- Qty 4 - 4.5m wire rope Guys with shackles fitted at looped end
- Qty 8 - Rigging Screws
- Qty 4 - 'D' Shackles
- Qty 8 - Thimbles
- Qty 24 - Wire Rope Grips

Sectioned Tower kit CA-12/08

- Qty 1 – Tube Top Section
- Qty 1 – Tube Middle Section
- Qty 1 – Tube Bottom Section
- Qty 2 – Tube Joiners

WHAT YOU WILL NEED

- Tape Measure
- Spade
- Concrete for foundations
- 13mm AF Spanner
- 17mm AF Spanner
- 8mm AF Spanner
- Spirit Level

Other Items you will need if not using Sectioned Tower Kit

- 6.5m length of 40mm Medium (3.2 wall) galvanised tube.
- Electric Drill
- 10.5mm Drill
- 8.5mm Drill

SITING

General Considerations

The location and height of the mounting pole or tower for your wind turbine will be the major factor in the overall performance of your system.

The smooth flow of wind over land and water is often interrupted by a multitude of obstructions causing wind shear and turbulence.

Wind shear describes the interference between the fast moving upper air and the slow moving air close to the ground and the resulting decrease in average wind speed as one gets closer to the ground.

Turbulence is caused by the wind passing over obstructions such as moored boats, trees and buildings. Both wind shear and turbulence diminish with height and can be overcome simply by putting the machine sufficiently high above them.

It is therefore essential that the wind generator should be located in an area as free as possible from disturbed wind flow. Bear in mind that downwind obstructions can be as detrimental to performance as upwind obstructions (Fig.1).

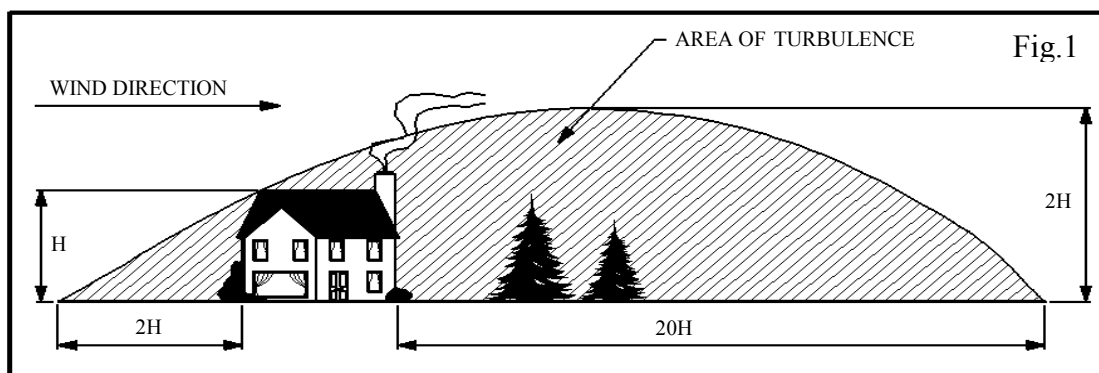

FOUNDATIONS

Note: The foundation dimensions given below are minimum based on normal compacted cohesive soil, for other soil types the foundations should be designed accordingly. If in doubt consult a civil engineer.

Mark out & dig holes for the tower base & four guy anchor points as shown in the diagram below:

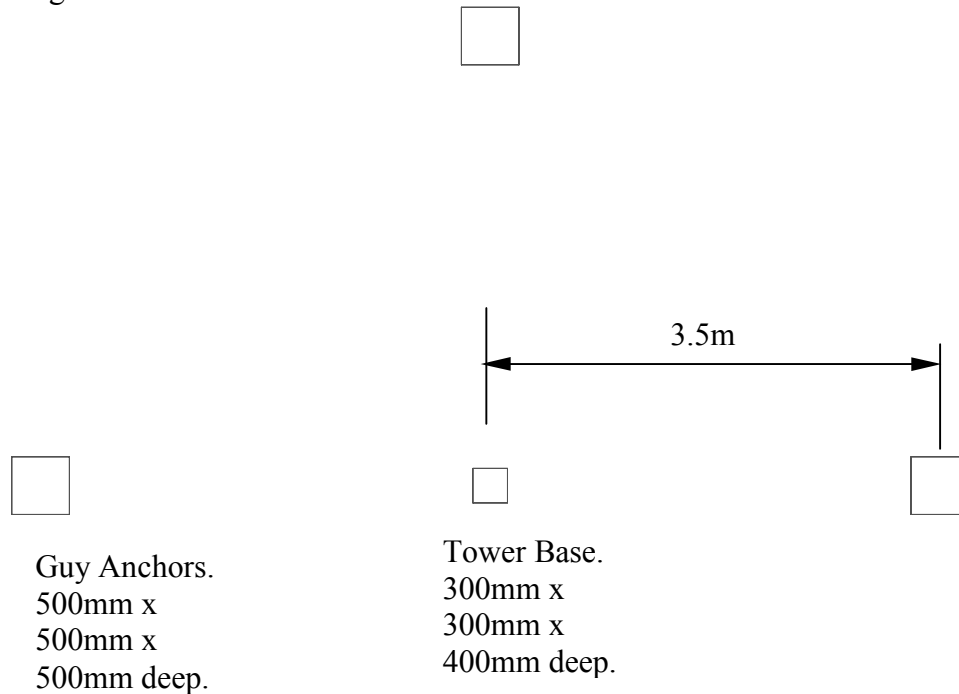

Fig 2

For added security, slope the sides of the holes outwards as shown in Fig 3

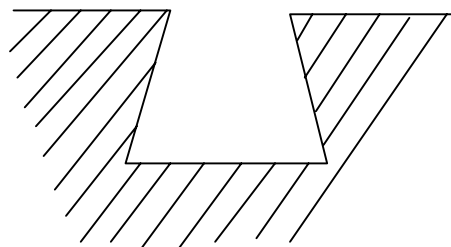
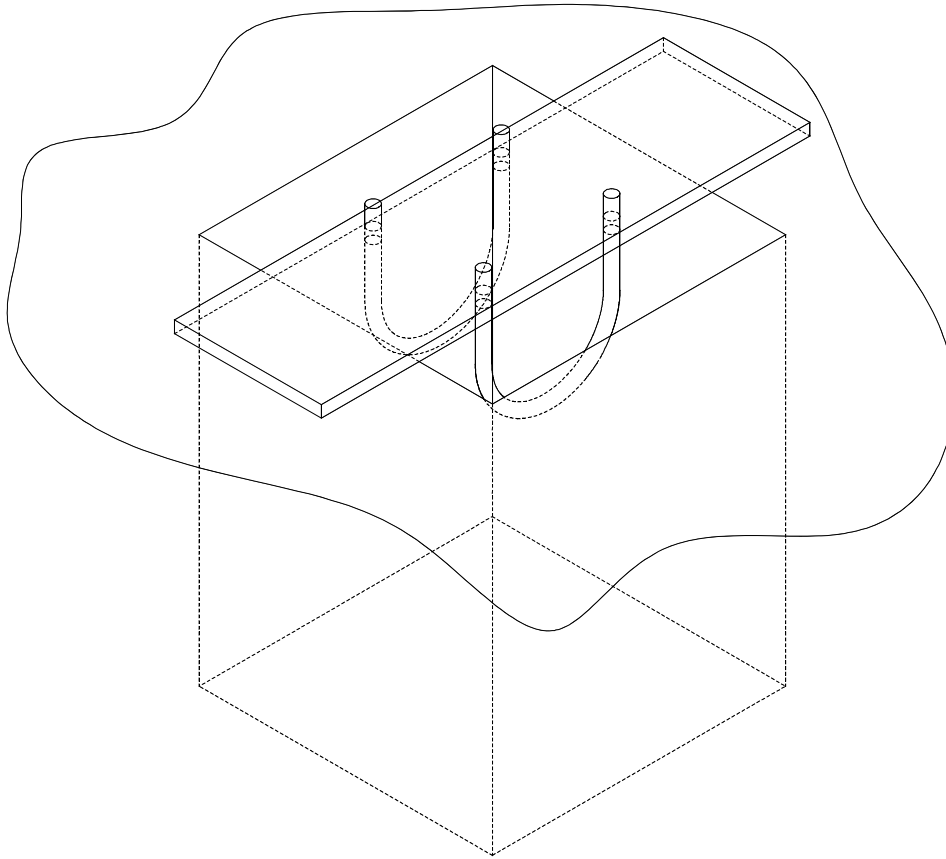

Fig 3

Tower base

Suspend the 'U' bolts centrally in the hole in the correct position & orientation. This can be achieved using a suitable piece of wood which will span the hole, drill four holes $\text{\O}12$ using the tower base as a guide, insert the 2 base foundation 'U' bolts through the holes & fit the 4 nuts ensuring that approx 30mm of thread protrudes above the concrete. Foundation bolt spacing is 131 x 113mm.

Check for correct spacing of the foundation bolts by positioning tower base brackets on the protruding threads & laying tower tube between the brackets prior to mixing concrete.

**Fig 4**

Guy Anchors

Select a suitable piece of wood which will span the hole, drill 1 hole $\text{\O}10.5$ mm through and secure the ground anchor to the wood at an angle of 45° using a suitable bolt as shown in fig 5, suspend in the hole as shown ensuring they are in the correct position & orientation.

Mix approx 0.5m^3 of concrete & fill the five holes ensuring the concrete is well packed down & air removed.

Ensure all inserts are correctly positioned & allow to harden for 2 days.

Note: The holes can be filled with concrete first and the foundation bolts & ground anchors pushed in immediately afterwards if this is found to be easier.

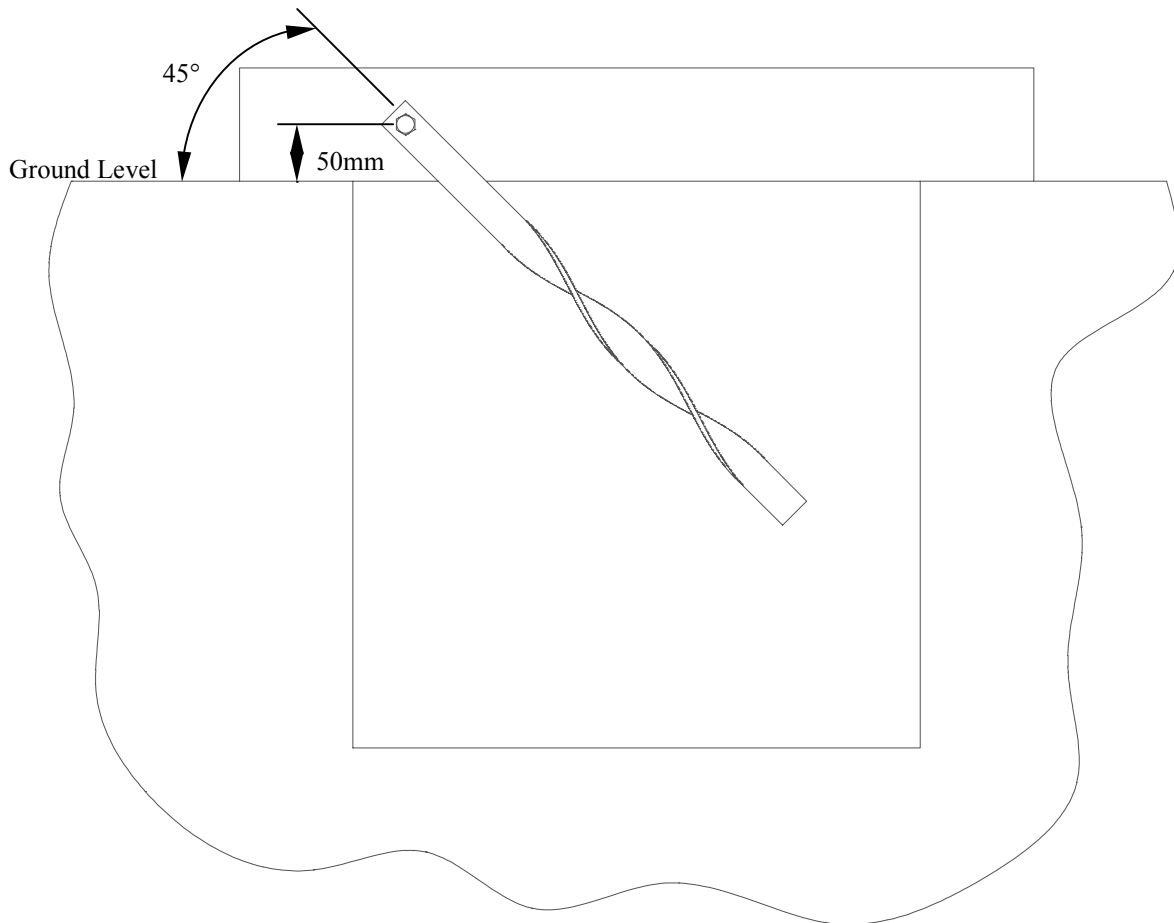

Fig 5

TOWER PREPARATION

Using single 6.5m length of tube (not supplied) (Appendix A)

- Drill tube as shown on drawing in Appendix A.
- Insert 1 M8 x 65 bolt through the 8.5 hole at the lower guying position, fit & tighten an M8 lock nut, orientate the nut & bolt so that the flats face the ends of the tube.
- Slide one of the guy plates over the top of the tube with the angled corners pointing down, until it stops against the M8 nut & bolt.
- Repeat the procedure for the upper guying point.

Using sectioned tower kit CA-12/08 (Appendix B)

See Appendix B for correct orientation of the tube sections.

- Insert M8 x 65 bolts through the 8.5 holes in the top & middle sections of tube, orientate the nut & bolt so that the flats face the ends of the tube.
- Slide guy plates over the top of the top & middle sections of tube with the angled corners pointing down, until they stop against the M8 nuts & bolts.
- Join the 3 sections of tube using the joiners provided.

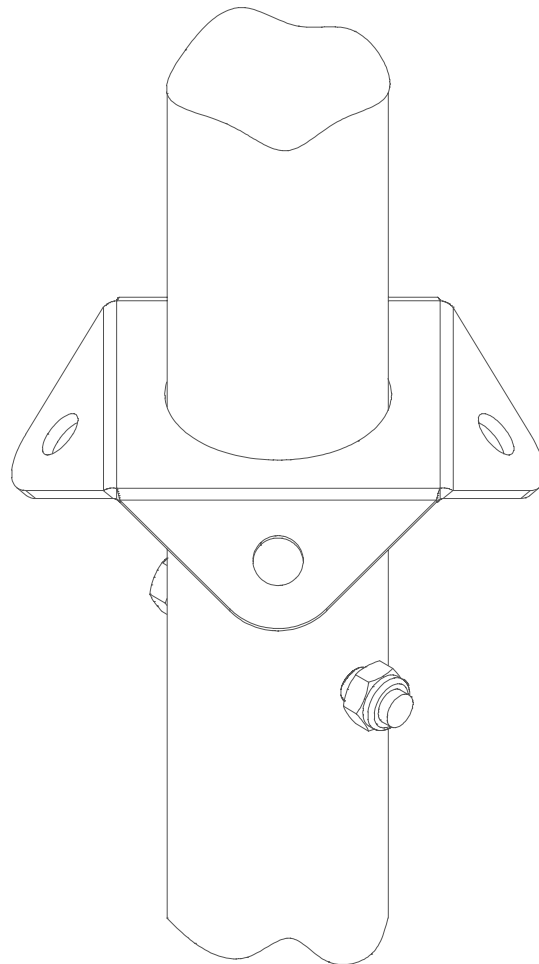

Fig 6

ASSEMBLY

Place the Tower Base over the four threads protruding from the concrete foundation, ensuring the pivot is orientated correctly. Fit the Nuts & washers & securely tighten.

Lay the tower tube in position on the ground with it's bottom end in the tower base & insert the M10 x 70 bolt, secure with the washer & nut ensuring the tube is free to pivot.

Attach the guys to the guy plates with the shackles through the looped ends of the guys, the 6.5m guys are fitted towards the top of the tube, the 4.5m guys towards the bottom.

Fit the remaining 4 shackles to the guy ground anchors. Place the hooked ends of 2 of the rigging screws through the shackles on the side anchor points. Open the rigging screws to approx $\frac{3}{4}$ their maximum length.

Take the 2 upper side guys & pass the free ends through the looped ends of the rigging screws & around the thimbles pulling the cables to remove the slack, secure in position using 3 rope grips on each guy. Repeat the procedure with the fore & aft guys by laying them alongside the side guys to achieve the same length.

Note: If the ground is uneven or not level, the guy lengths may differ.

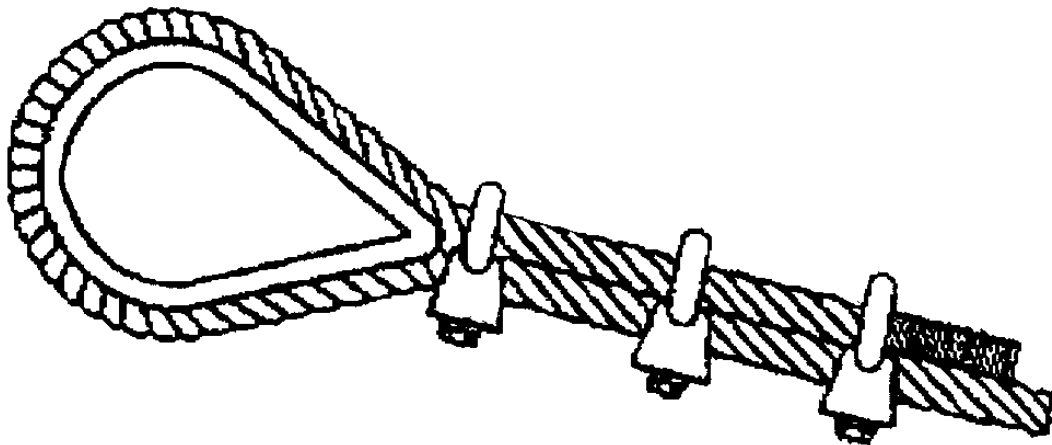

Fig 7

The first rope grip must be placed immediately against the thimble. The grips must be placed so that they are separated by a minimum distance of 30mm. The 'U' bolt must always be placed on the tail end of the rope ie non load bearing end.

Hook the rigging screw into the shackle on the anchor point for the rear guy, ie the anchor point covered by the tower.

ERECTION

Erection should only be attempted in light winds.

The tower should first be erected without the wind generator fitted.

Raise the tower to it's working position by pivoting about it's base fixing. **Ensure the rear rigging screw does not become detached from it's anchor point.** Attach the free guy to it's anchor point to secure the tower in it's vertical position.

With the aid of a spirit level, adjust the rigging screws until the tower is vertical & the guys are suitably tensioned.

Attach the 4 lower guys to their rigging screws by looping the free end through the eye of the rigging screw and thimble & secure using 3 rope grips. Tension as for the upper guys.

Ensure the tube is straight & vertical.

The tower can now be lowered by reversing the procedure for raising. It may be necessary to slightly slacken the side guys during this procedure.

The wind generator cable can now be installed down the centre of the tower & the wind generator fitted to the tower top. The tower can be raised in the same manner as previously & guys tensioned ensuring the tower is straight & vertical.

After tensioning of the guys, the rope grip nuts should be checked for tightness, this should be repeated after 24 hours. Further periodic checking & tightening of the nuts is essential during service, more frequently during early stages of operation to ensure long term reliability of the structure.

Appendix A
Tube Drilling Detail

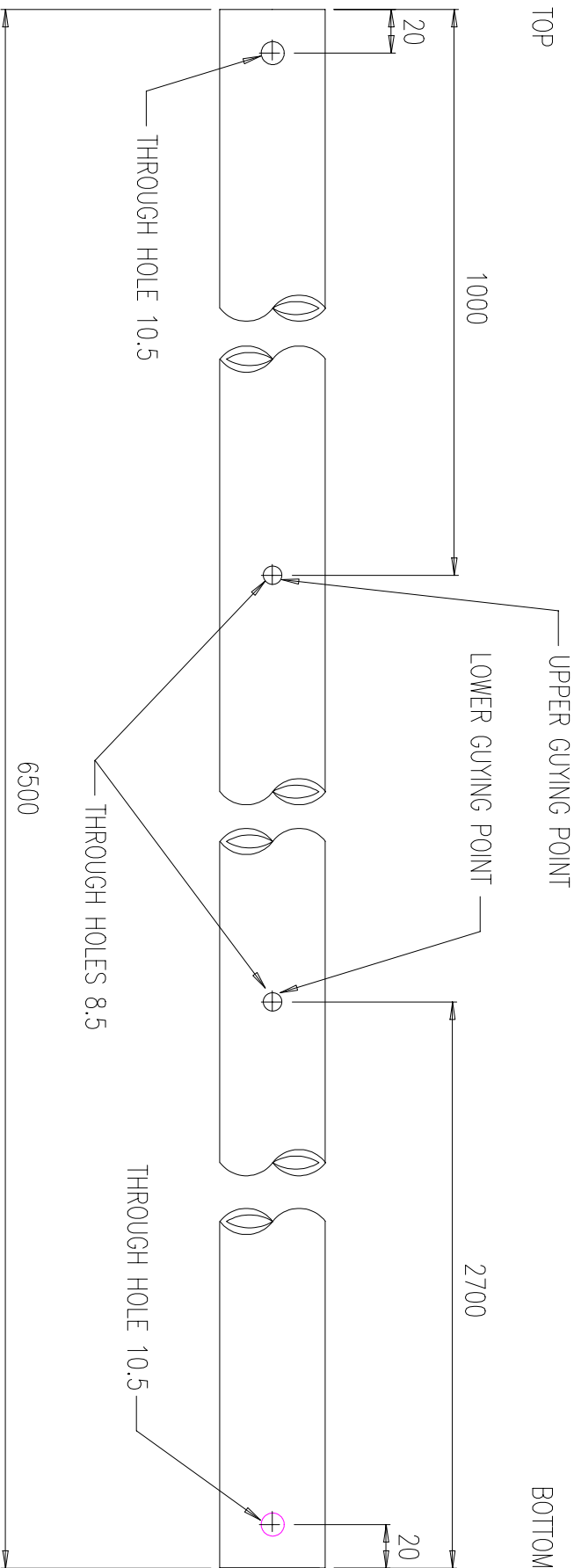

Appendix B
Sectioned tube kit

