

# INSTRUCTION MANUAL

-----For controller,  
With optional remote meter



## **CHARACTERISTICS**

- LCD display: all systems parameters, system status as symbols Intelligent software control.
- PWM charging mode
- Battery type option
- Battery Ah (Amp hour) setting
- Over-load, short circuit, polarity reverse protection, electronic fuse
- Temperature compensation setting
- Modify parameters using four keys

## **TECHNICAL INFORMATION**

Type	(10A)	(20A)
System voltage	12V/24V	AUTOSET
Rated charging current(IE)	10A	20A
Rated load current	10A	20A
Over load, short circuit protection	1.25 times of IE for 60 seconds, 1.5 times of IE by for 5secs overload protection; $\geq 3$ times of IE short circuit protection	
Self consumption	$\leq 6\text{mA}$	
Charging circuit voltage drop	$\leq 0.26\text{V}$	
Discharging circuit voltage drop	$\leq 0.15\text{V}$	
Work temperature	Industrial(I series); $-35\text{ }^{\circ}\text{C}$ to $+55\text{ }^{\circ}\text{C}$ ; commercial $:-5\text{ }^{\circ}\text{C}$ to $+50\text{ }^{\circ}\text{C}$	
Temperature compensation	$0-10\text{mv}/^{\circ}\text{C}/2\text{V}$	
Control mode	PWM charging mode	
Remote meter LCD specification		
Working current	Strong backlight on $< 23\text{mA}$ , 15 seconds	

	Low backlight on < 20mA, 15 seconds Backlight and LED indicator off < 15mA
Working temperature	-10°C to +40°C
Communication port	RJ45 ( 8 PIN)
Communication cable	1.5 meters

## INSTALLATION

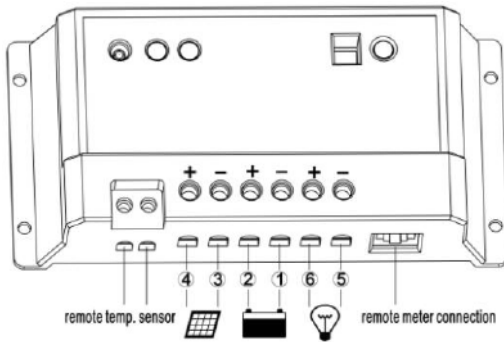

**Connect the individual components to the symbols provided, they are solar panel, battery and loads in order indicated 1-6.**

Install the regulator near the battery, the installation environment should be indoor dry and nonflammable. If used outdoors, ensure the location is waterproof and dust proof. The cable should be as short as possible and have a suitable cable diameter to minimize loss, e.g. use 2.5 mm<sup>2</sup> at 10A; use 5mm<sup>2</sup> at 20A.

1. Mount the controller and meter. Allow space above and below the controller for air flow. Connect the controller and meter by the communication cable.
2. Connect the battery to the controller. **Note the plus and minus connections.** If the connection is correct, the battery indicator will be on.

***Please note: We suggest fitting a inline fuse to the battery to protect against short circuit. The fuse rating should be rated above the controllers rated current.***

3. Connect the photovoltaic module to the charge regulator, note plus and minus. If there is light, the charging indicator should be on.

***Note: when solar panel is in bright sunshine, the voltage may be harm full . Cover the panel while maintenance or repair are carried out.***

4. Connect the load to the charge controller: press ON/OFF button. Ensure off status, note the plus and minus.
5. Remote temp. sensor(RTS): A connection point for RTS(OPTION) to remotely monitor battery temperature. Local temp. sensor: Measure ambient temperature. Battery regulation is adjusted accordingly.

***Note: where there is no RTS, the controller will calculate the data from the controllers temperature sensor. The controller will use the RTS automatically when the RTS is connected.***

## MECHANICAL DRAWING

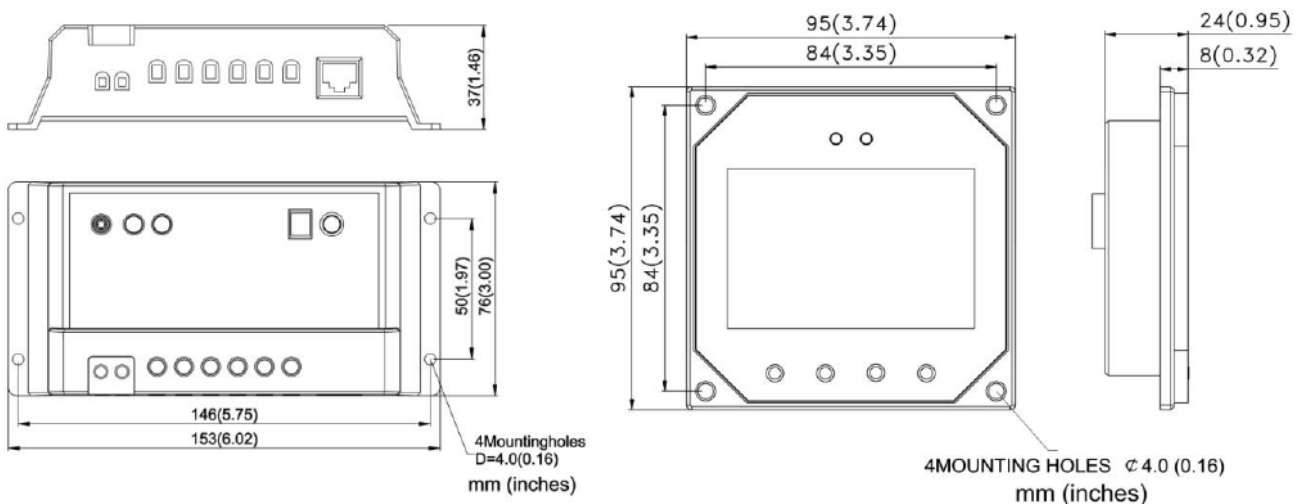

## CONTAINS

Wall mounting board, can be mounted in or on the wall. With 1.5 meter cable

## REMOTE METER DISPLAY

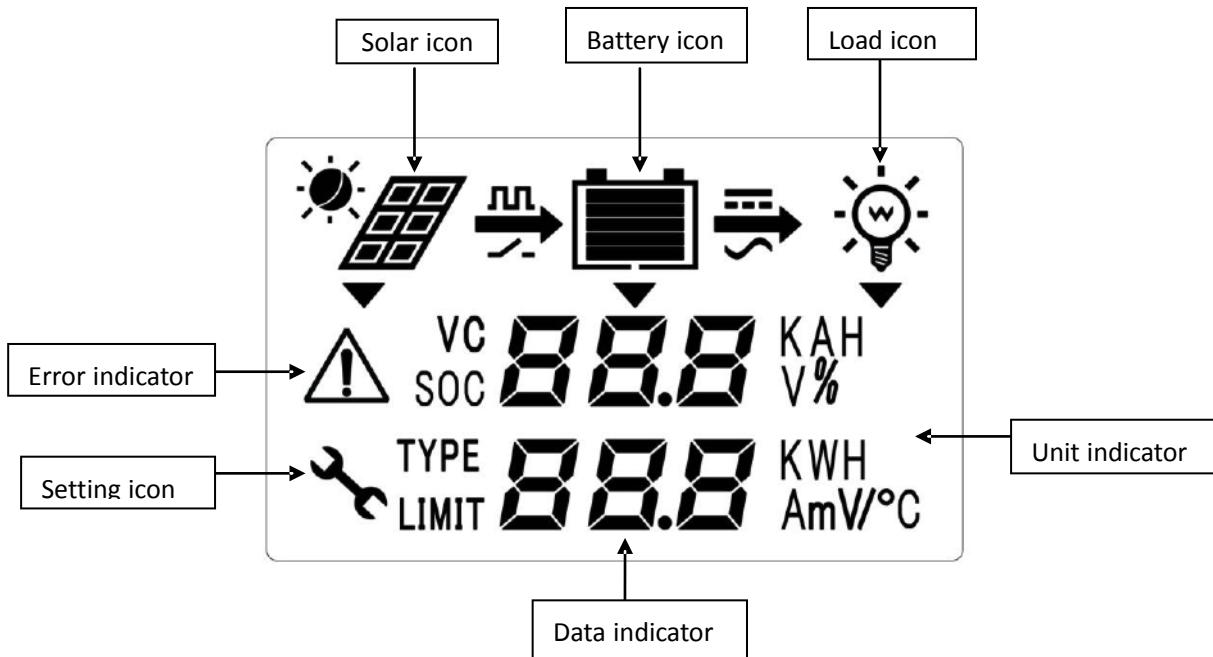

Two LED's above the LCD display, green is on when charging. Yellow is on when there is an error.

The meter backlight has 2 positions, bright for 15 seconds and then dims. After 15 seconds, the backlight switches off.

## REMOTE METER OPERATION INSTRUCTION

The keys from left to right are: K1-K4, or Set, Left  $\leftarrow$ , Right  $\rightarrow$ , ON/OFF/ESC

### 1. The meter displays information in the following order:

(solar panel voltage, solar panel charging current), (battery voltage, charging current), (load voltage, load current), (battery capacity AH, battery temp.), (battery capacity percentage, temp. compensation), (battery capacity AH, battery type), (charging accumulation AH, charging accumulation WH), (discharging accumulation AH, discharging accumulation WH). Use K2, K3, or Left, right key to display the individual data. Data shows as following pictures.

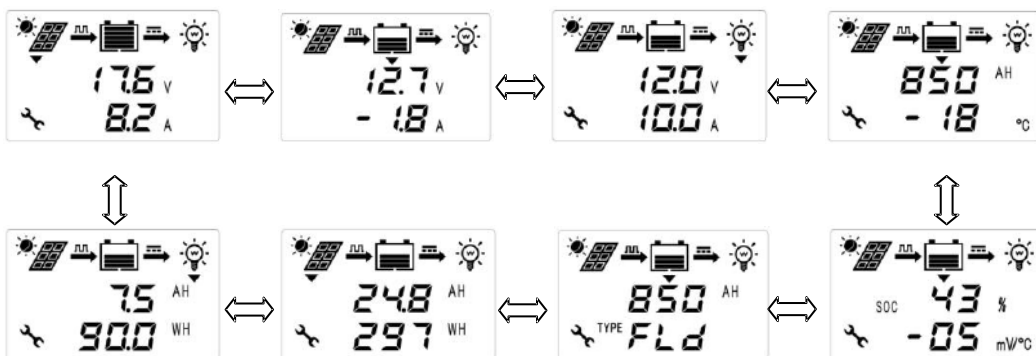

 is setting icon. It appears in setting status, and disappears in reading status.

### 2. Data setting operation:

Reading status, press K1/SET to setting status, press K2, K3 to modify data. K1 for back to reading status and saving data. K4 for back to reading status without saving data. Only battery voltage and current can't be set.

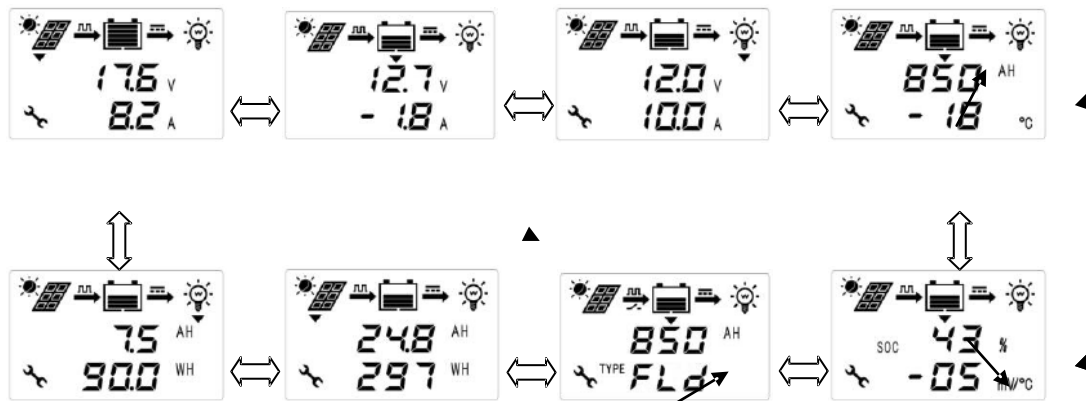

The data that can be adjusted : battery capacity AH, battery temp. compensation , battery type.  
On read status, press K1/SET for setting data.

### 3. Data setting instructions

**Battery capacity :** capacity can be set from 10AH to 900AH, the default value is 200AH. The modified data should be near or equal to the real capacity. While displaying battery capacity and temp., press K1 into setting mode, modify the data through K2, K3. Battery capacity will go up/down by 10AH, press K1 for saving data and back to the reading status. Or press K4 to go back to reading status without saving. The capacity will remain the same.

**Battery temp. compensation:** temp. compensation data modification ranges from 0 to 10mV/Cell/°C while the data is 0, there is no temp. Compensation function. While displaying battery capacity percentage, temp. compensation, press K1 into setting mode, modify the data through K2, K3. The temp. compensation will be up/down 1 mV/Cell/°C.

**Battery type:** battery type has three option: SEL-sealed battery, GEL- gel battery, FLD- flooded battery. While displaying battery capacity percentage, temp. compensation, press K1 into setting mode, choosing suitable battery type through K2, K3.

### 4. Other operations:

Delete accumulated data: while displaying charging discharging accumulation, press K4/SET, then press K1/ESC, the data will be deleted. The controller will delete the data automatically. The accumulation starting point will be when

## OTHER INSTRUCTION

**Error icon instruction:** red flashing LED error status. Please check the load connection, press K4 to delete error icon.

1. when load current is over 1.25 times and less than 1.5 times of rated current, load will switch off automatically after 60 seconds.
2. When the load current is over 1.5 times of rated current but less than short circuit the load will switch off automatically after 5 seconds.
3. When load current is short circuit, the short circuit protection will switch off the load.

### LED indicator:

Green is on when the solar panel is charging the battery. When the green LED is off there is no charge.

Yellow on when there is error. Yellow off in normal status.

### Telecommunication port:

When the meter is run by a individual supply or the communication is cut off, it will display graphical symbols.

When a key is pressed there will be no data displayed. The data will be displayed when communication is resumed.  
Note: If there is no data displayed, check the communication cable is correctly fitted, or there could be interference. If the cable run is long, this may display corrupt or incorrect data..

**Battery capacity strip flash:**

Each strip equals to 20% of battery capacity.

Note: the calculation takes fully charged voltage as 100%, and over discharge as 0%. All is based on battery voltage, not the real battery capacity.

Serial communication happens every 10 seconds between controller and the remote meter, the data update can take 10-20 seconds.

**Battery capacity AH:**

AH is the accumulation of charging, every minute will count. The data is not accurate while the charge current is too small. The min. is 1AH, means 1 amps charging for 1 hour.

**Charging and discharging accumulation WH:**

WH is product of battery voltage and charging current accumulation.