

INSTRUCTION MANUAL

-----For solar charge controller,

IP67 Rated

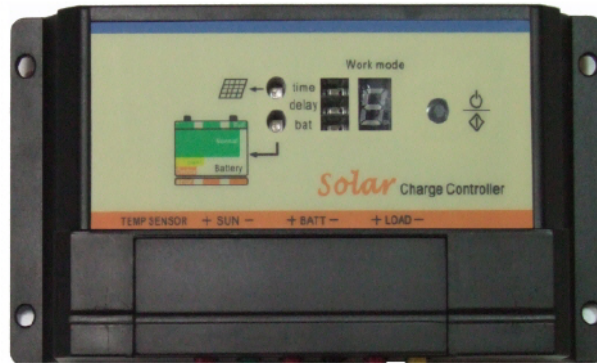

RATINGS (12V or 12/24V auto work)

12V or 12/24V auto-work, 10Amp

NOTES: For use with solar panels only

TECHNICAL INFORMATION

	12Volt	24Volt
Rated solar input	10A	10A
Rated load	10A	10A
25% Current overload	1 min.	1 min.
Load disconnect	11.1V	22.2V
Load reconnect	12.6V	25.20V
Temp Comp.(mV/°C)	-30mV	-60mV

Temperature: -35°C to +55°C

	sealed	flooded	Gel
High voltage disconnect	14.2V	14.4V	14.6V
Equalization voltage	14.4V	14.6V	14.8V
Float voltage	13.7V	13.7V	13.7V

QUICK START INSTRUCTIONS

This section provides a brief overview of how to get started using the controller. However, please review the entire manual to ensure best performance and years of trouble-free service.

1. Mount the controller on a vertical surface. Allow space above and below the controller for air

flow.

2. Make sure the PV and load current does not exceed the ratings of the controller being installed.
3. It is recommended that the connections be made in order. (see the following).

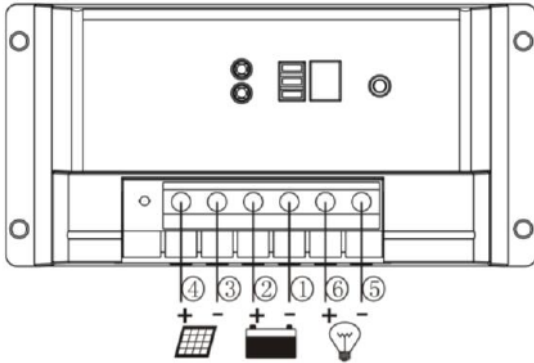

Use with 12V or 24V batteries only
Use with 12V or 24V systems only

4. Connect the **BATTERY** first. It is needed that the bare wires do not touch the metal case of the controller.
5. Connect the **SOLAR**(PV array) next. The green LED indicator will light if sunlight is present.
6. Connect the **LIGHT** last. If the red LED indicator lights, the battery capacity is low and should be charged before completing the system installation
7. Press the Setting key and select **5**. to verify the load is working on/off.

LIGHTING CONTROL OPTIONS

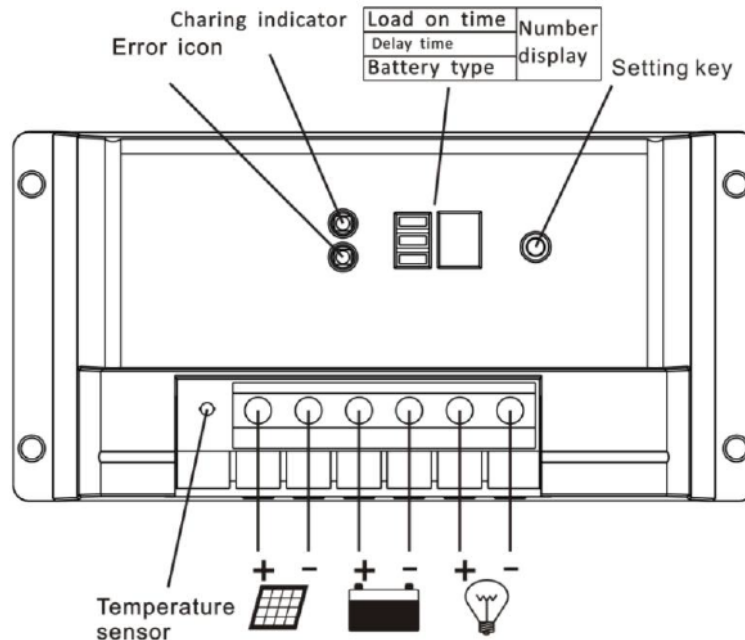

LIGHTING CONTROL OPTIONS

LOAD ON TIME SETTING:

Press the setting key, and the led will scroll from **LOAD ON TIME SETTING, DELAY TIME SETTING and BATTERY TYPE SETTING**. Press the key for 5 seconds when the led is on **LOAD**

ON TIME SETTING, the number will flash. Select a number from the table below, wait until the LED stops flashing.

0	Dusk-to-Dawn, light is on all night
1	Light is turned on for 1 hour after sundown
2	Light is turned on for 2 hours after sundown
3	Light is turned on for 3 hours after sundown
4	Light is turned on for 4 hours after sundown
5	Light is turned on for 5 hours after sundown
6	Light is turned on for 6 hours after sundown
7	Light is turned on for 7 hours after sundown
8	Light is turned on for 8 hours after sundown
9	Light is turned on for 9 hours after sundown
0.	Light is turned on for 10 hours after sundown
1.	Light is turned on for 11 hours after sundown
2.	Light is turned on for 12 hours after sundown
3.	Light is turned on for 13 hours after sundown
4.	Light is turned on for 14 hours after sundown
5.	Lights remain turned off, ON/OFF mode

DELAY TIME SETTING:

Press the key for 5 seconds when the led is on **DELAY TIME SETTING**, the number will flash. Select a number from the table below, wait until the LED stops flashing.

0	Without any delay, lamp is on after dusk.
1	Since its dusk, the lamp will be on after 10 minutes.
2	Since its dusk, the lamp will be on after 20 minutes.
3	Since its dusk, the lamp will be on after 30 minutes.
4	Since its dusk, the lamp will be on after 40 minutes.
5	Since its dusk, the lamp will be on after 50 minutes.
6	Since its dusk, the lamp will be on after 60 minutes.
7	Since its dusk, the lamp will be on after 70 minutes.
8	Since its dusk, the lamp will be on after 80 minutes.
9	Since its dusk, the lamp will be on after 90 minutes.

BATTERY TYPE SETTING:

Press the key for 5 seconds when the led is on **BATTERY TYPE SETTING**, the number will flash, Select a number from the table below, wait until the LED stops flashing.

1	Seal lead acid battery
2	Flooded battery
3	Gel battery

LED INDICATOR

Charging indicator	Green ON when solar is charging battery
--------------------	---

Green flashes when the system over voltage

Error Icon

Red ON when battery level in the right range

Red slowly flashing when its over load

(the load amps is 1.25 times of rated current for 60 seconds, or the load amps is 1.5 times of rated current for 5 seconds)

Red blink when the load is short-circuit.

Please note:

1. the output will cut off once there is over load or short circuit. Disconnect all the loads, press the power switch, or wait until the next day, the controller will resume to work automatically.
2. If its on ON/OFF MODE, press the key, and this will erase the error, the output will be on after the button is pressed again.

TROUBLESHOOTING

1. Charging LED indicator is off when it is daytime
 - a. The green Charging LED should be on during the day.
 - b. Check that the proper battery type has been selected.
 - c. Check that all wire connections in the system are correct and tight. Check the polarity(+ and -) of the connections
 - d. Measure the PV array open-circuit voltage and confirm it is within normal limits. If the voltage is low or zero, check the connections at the PV array itself. Disconnect the PV from the controller when working on the PV array.
 - e. Measure the PV voltage and the battery voltage at the controller terminals. If the voltage at the terminals is the same(within a few tenths of volts) the PV array is charging the battery. If the PV voltage is close to the open circuit voltage of the panels and the battery voltage is low, the controller is not charging the batteries and may be damaged.
2. Charging LED indicator is blinking
 - a. First check the operating conditions to confirm that the voltage is higher than specifications. Consider the temperature compensation of the controller s PWM setpoint. For example, at 0°C the controller will regulate at about 15.1 volts
 - b. Check that all wire connections in the system are correct and tight.
3. Error icon is blinking, or flashing or on red(load not operating properly)
 - a. Check that the load is turned on. Check that no system fuses are defective.
 - b. Check connections to the load, and other controller and battery connections. Make sure voltage drops in the system wires are not too high.
 - c. If the LED indicator is blinking and no output, check if the load is short-circuit. Disconnect the load, and press the switch button, the controller will return to work after 30 seconds.
 - d. If the LED indicator is flashing and no output, check if the load is over the rated power. Reduce the load, and press the switch button, the controller will return to work after 30 seconds.

INSPECTION AND MAINTENANCE

The following inspections and maintenance tasks are recommended at least once per year for

best controller performance.

1. Confirm that the correct battery type has been selected.
2. Confirm that the current levels of the solar array and load do not exceed the controller ratings.
3. Tighten all the terminals. Inspect for loose, broken, or burnt wire connections. Be certain no loose strands of wire are touching other terminals
4. Press the setting button on/off when in mode
5. To verify the load is working.
6. Check the air flow around the controller is not blocked.
7. Protect from sun and rain. Confirm that water is not collecting under the cover
8. Check that the controller functions and LED indicators are correct for the system conditions at that time.
9. Make sure the PV array is clean and clear of debris and snow. Confirm the array is oriented correctly for the installation location.

SYSTEM MAIN CIRCUIT DIAGRAM

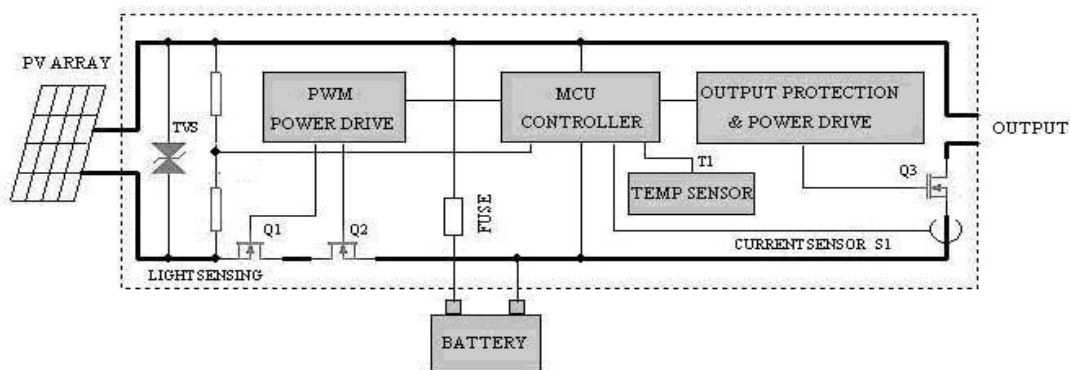

MECHANICAL

