

New Rutland 504!



The Rutland 504 Windcharger

Free and abundant wind power keeps your batteries topped up and ready to start....

Rutland Windchargers simply convert the free and abundant power in the wind to power stored in your batteries. The 12V power is ready to use for engine starting, lights, coolers, essential navigation equipment and other low energy appliances. With a Rutland 504 installed on board weekend sailors will experience the convenience of fully charged batteries for engine starting.



What's new in the Rutland 504?

- The Rutland 504 features new aerodynamic styling.
- A sharper nose dome to improve the flow of wind to the turbine
- A longer tail fin to improve the orientation of the turbine to wind and maintain stability.
- Higher grade body and nose material with improved UV stability and durability.



The Rutland 504 Windcharger is ideal for trickle charging on board.



Rutland Windchargers are renowned for their quiet and continuous operation.

Rutland Windchargers are a popular sight in marinas, thousands are in use worldwide and boat owners like their particularly quiet operation coupled with clean, aerodynamic lines.

Without doubt the unique Rutland alternator design accumulates more energy than any other comparable wind generators available and you'll always see a Rutland spinning in the lightest of breezes!

The Rutland 504 model continues to incorporate the “safety turbine” found on its highly successful predecessor the Rutland 503. The blade tips are protected by the outer ring making this windcharger ideal for trickle charging on board where space is at a premium. Weekend yachts and sailboats up to 10m benefit from its compact size and charging capacity and in particular where batteries up to 100Ah are in regular use.

Motor home and touring caravan owners will find the Rutland 504 conveniently portable and ideal for topping up the battery when parked.

When you fit a Rutland Windcharger on board you will experience:

- Direct savings on fuel costs and engine maintenance owing to reduced engine running time
- Security of power for essential appliances on-board, eg. navigation equipment
- Fully charged batteries for engine starting on returning to your boat.

.....and don't forget that by keeping your battery trickle charged its life will be extended too!

Rutland 504 Windchargers are also found on:

- Inland boats
- Motor Cruisers
- Caravans
- Motor homes

Modern, durable materials for reliability on the high seas accompany the very high manufacturing standards employed in our ISO9002 certified factory.

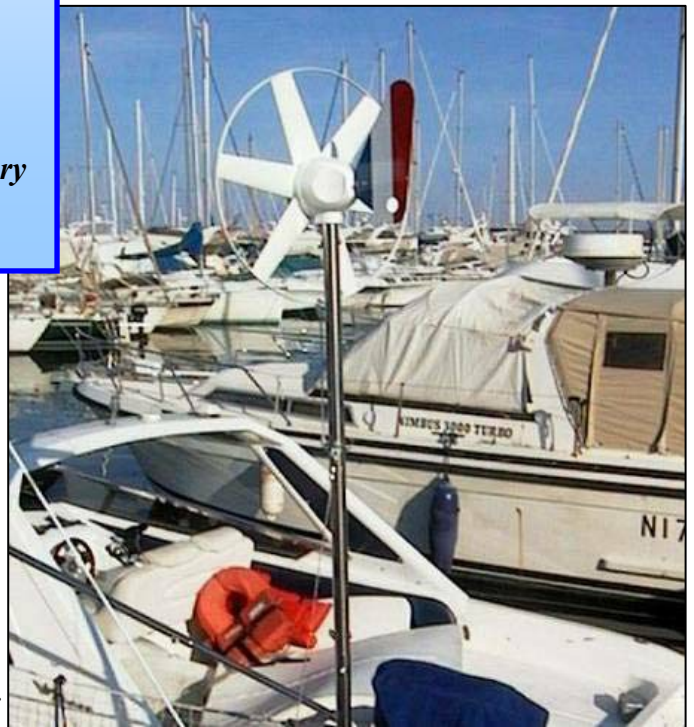

Rutland 503 keeping a motor cruiser's battery topped up and ready to start.



Solar Power too!

Windchargers are complemented by solar panels for power generation. Hybrid systems offer a reliable solution for providing a balanced supply of power throughout the seasons and to take advantage of the various climates around the world.

Features & Benefits

- Efficient power conversion – Rutland Windchargers generate greater ampere-hours in real wind conditions than turbines of equal and often larger diameter! That's because between gusts, our unique high inertia alternator designs maintain momentum with a flywheel effect where other units stall. This adds up to more free power generated and stored for you.
- Rutland Windchargers are the lowest cost per watt of power generated.
- Low friction 3-phase alternator gives a smooth and silent output. The low wind speed start up means power is almost continuously produced and certainly in the most typical conditions as well as being powerful in higher winds.
- Rutland 504 turbines are made from computer designed efficient aerofoil blades whose tips are joined by an outer protective ring.
- No radiated interference. Complies with EEC Directive 89/336/EEC

Specifications:

Output Graph:

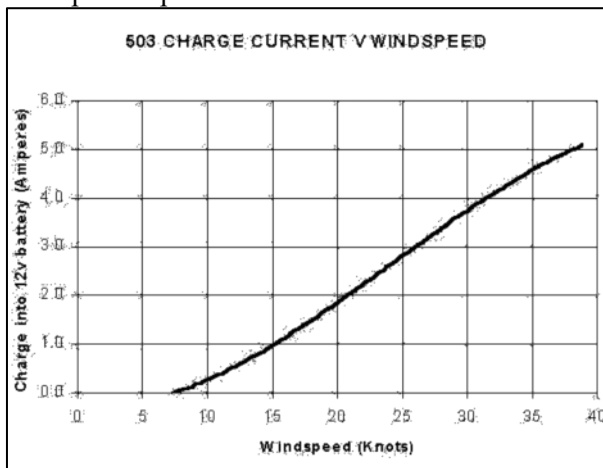

Dimensions:

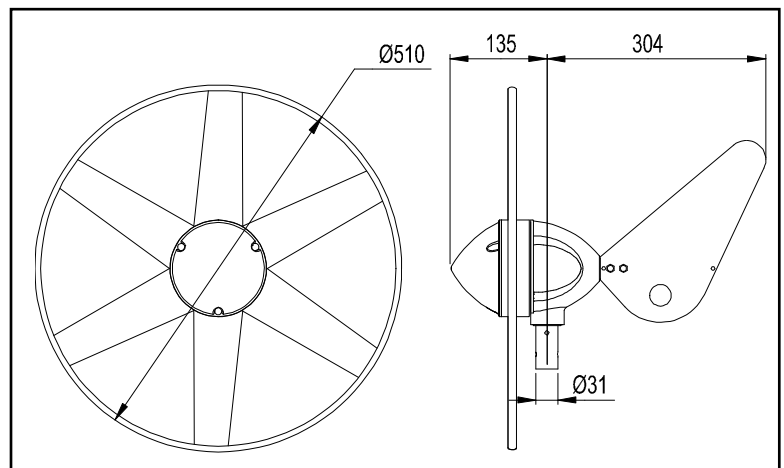

Low wind speed start up of just 5 Knots. Generates 25W @ 19 knots, 6W @ 10 knots and up to 80W.

**Net Weight: 3.5Kg Gross Weight: 6Kg
Packing Specifications: 550x550x260mm
Part No: CA-05/02 (12V)**

What else is needed to complete a system?

Marine Mounting Kit – a stainless steel mounting kit with deck bracket and guy fasteners (guys not included) is available or a mount may be constructed using a tube of 31mm internal diameter (max external diameter 37mm). Short sections of tube to affix to user's own pole are also available.

Land Tower & Rigging Kit – a 4m tower made of 2 sections, ground spike and rigging kit for temporary land installation. Ideal for temporary installation on motor homes and caravans. NB. There are other Rutland Windchargers designed for professional land uses, contact Sunshine Solar to discuss.

Voltage Controller – To avoid overcharging choose from the HRS503 Regulator, the HRSi Regulator or the HRDi Controller which has a digital display and dual charging facility and inputs for both windcharger and solar panels. See individual datasheets for more details.

Cable – for installations using less than a 20m run of cable we recommend 2.5mm² cable.

Batteries – Deep cycle or leisure batteries are recommended. Gel and Absorbed Glass Matt ranges are also available.

For expert system advice and to discuss your power requirements call our technical sales team.

Sunshine Solar Limited

Unit 30, Ashwellthorpe Industrial Estate

Ashwellthorpe, Norwich, Norfolk NR16 1ER

Tel: 01508 488188

