

Thank you for selecting the parallel adapter. Please read this manual carefully before using the product.

PAL-ADP-50AN Parallel Adapter

1. Overview

The PAL-ADP-50AN is a parallel adapter for adjusting the charging current of multiple controllers connected to the battery in parallel, which monitors the charging and operational status in real-time. The adapter automatically changes the controllers' charging and operational status according to the battery level to prolong the controller lifetime.

Features:

- Achieve the consistency of parameters for multiple controllers
- Equalize charging feature to smart control the charging current of each controller
- Monitor the working status and smart control the operation quantity of the controller
- Up to 6 controllers are supported
- Standard Modbus communication protocol and related PC Monitoring Software
- The 1-click setting for baud rate switch between 9600 and 115200
- LED indicator for operational status

2. Structure

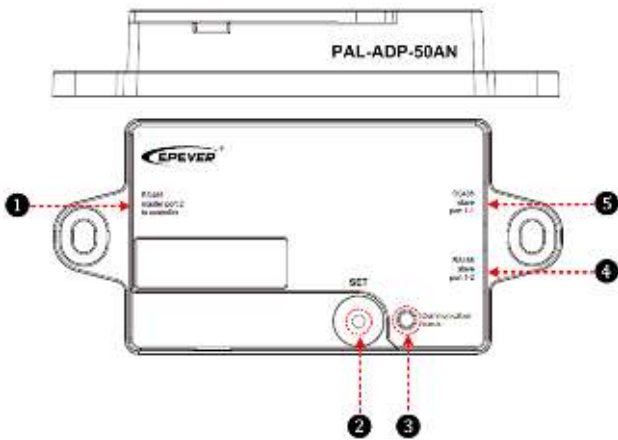

① RS485 communication port 1(RJ45)

Communicate with up to 6 paralleled controllers.



Accessories(included):

Communication cable (Model: CC-RS485-RS485-200U)

②SET button

Press and hold the button for 5 seconds to set the communication baud rate

- 9600—— Red LED indicator flash one time
- 115200——Red LED indicator flash two times

③Communication status indicator

- Solid Green——The adapter is working.

- Flash Green——Adapter is communicating.
- Flash Red——Adapter's baud rate indicator.

④⑤RS485 communication port 2/3 (RJ45)

These two ports are paralleled.

3. Product Application Connection Diagram

➤ Connection for Tracer AN (50-100A) series solar controller



NOTE: Set each controller ID to be different before wiring (ID Range: 1-10)

4. Power Switch Control

- The PAL-ADP-50AN will shut off one of the controllers. Simultaneously, the battery voltage reaches the target voltage (equalize, boost, float), and the average current is lower than 3Amps.
- The PAL-ADP-50AN will turn on one of the controllers until the average current is higher than 5Amps.

5. Charging Status Control

- The PAL-ADP-50AN will check the controller charging status. While one of the controllers turns into float charging mode, the rest controllers' boost charging time will change to 10 minutes.
- The controller is turning into float mode directly if the boost charging time reaches 10 minutes; otherwise, it will wait until the target time of 10 minutes.

IMPORTANT: In addition to the above rules, the boost charging recovery time will be 120 minutes in default.

6. PC Software Operation Instruction

Step1: Download the PC software and install the software.

Download address: <http://www.epever.com> >> SUPPORT >> SOFTWARE >> Charge Controller-windows.zip

Step2: Set the "controller ID."

- Port configuration >> Serial port setting



- Add the station

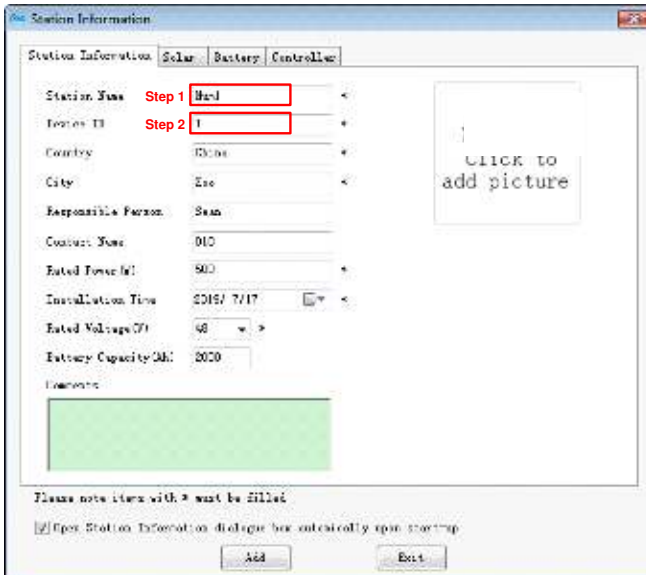

⚠ Caution: Only, one of the controllers, can be monitored at each time.

7. Specifications

Model	PAL-ADP-50AN
Apply to model	Tracer AN (50-100A) series solar controller
Input voltage	5VDC (Directly provided by the controller)
Operation power consumption	0.25W
Serial port baud rate	9600 115200(Default)
Overall dimension	151.5*69.9*25.7mm
Mounting Dimension	133.4mm
Mounting hole size	Φ6.5
Working temperature	-35~55°C
Enclosure	IP30
Weight	91.4g

⚠ Caution: The controller ID and device ID should be the same.

- Set the "Device ID"

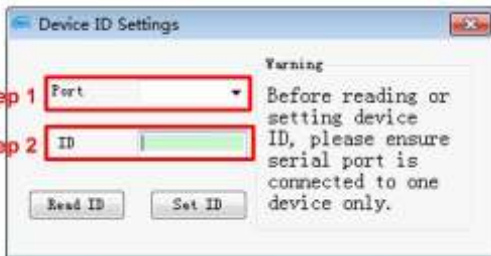

⚠ Caution: Only one of the controllers' IDs can be set at each time. Follow the same procedure to set the rest of the controllers.

Step3: Connect all controllers with the communication cable.

Step4: Add the rest of the controllers' ID to the station (Refer to step 2).



Step5: Monitor the operational data and status of each controller in real-time.

- Select the related controller >> start monitoring



8. Mechanical Parameters

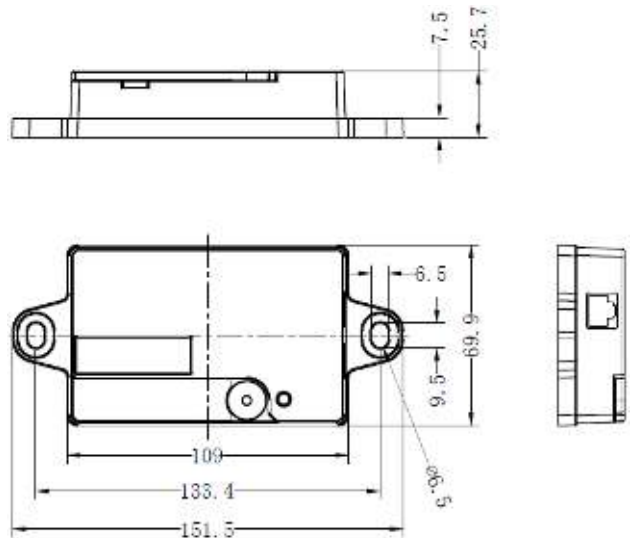

Any changes without prior notice! V3.0